



**Model Number** SS3-TN-56HC-2-D-1-230|460-60

**MFG PN** TSSN56H1U2B

**List Price** --

All data shown at HIGH voltage setting

Format STD 3 Phase

Electrical Data				General Data	
Rated Motor Output Power	1 HP			Frame Size	56
Rated Motor Speed	3510 r/min			Enclosure	TENV
Rated Motor Voltage (3 Phase)	230 460-60 Volts - HZ			Approximate Weight	42.9
Rated Motor Current	2.55/1.27 Amps			NEMA Design	B
Service Factor	1.25			IP Rating	69K
KVA Code	M			Insulation Class	F
Nominal Efficiency	86.2 %			Tropicalization	YES
Nominal Power Factor	0.85 cosθ			Duty	Cont.
Full Load Torque Ft-Lb	1.489952 Ft-Lb			Cable Entry	0
Temp Rise @ Full Load °C	51.3			Feet Removable	NO
Efficiency Level	IE3 - NEMA Premium			Double Drilled	0
Load Data	RPM	Trq %FL	Current Amps	Rated Ambient (°C)	40
Locked Rotor	-	337	10.77	Rated Altitude (M)	1000
Breakdown	-	437	-	Coating	unpainted - unpainted
Pull Up	-	260	-	Shaft Grounding	NO
125% of FL	3499	-	1.51	Brake Voltage (DC)	--
75% of FL	3542	-	1	Brake Torque (N-M)	--
50% of FL	3562	-	0.8	Mechanical Data	
No Load	--	-	0.57	Bearing DE Side	6205 2RS
Hazardous Location	--			Bearing NDE Side	6204 2RS
				Moment of Inertia	-- kg.m2
				Noise Level	Per NEMA dB (A)

CT VFD Range	--	<b>Loaded Torque Curves</b>	--
<b>P1 = INPUT POWER (KW), S = Slip (% of Sync RPM), η = Efficiency (%), cosφ = Power Factor</b>			

Certifications	UL	CSA	DOE
File Numbers	323353	224693	096A
Wiring Diagram	3PH 9 Lead Dual Voltage		

**3 Phase - YY/Y - 9 Lead**  
 4,1 Blue / 5,2 White / 6,3 Org / 7 Yl / 8 Blk / 9 RD  
 Cast Iron- 1,2,3 Top - 4,5,6,7,8,9 Bottom  
 Aluminum - 4,5,6,8,9 Top - 1,2,3,7 Bottom

CONNECTIONS					
4	5	6	4	5	6
7	8	9	7	8	9
1	2	3	1	2	3
↑ LOW VOLTAGE			↑ HIGH VOLTAGE		

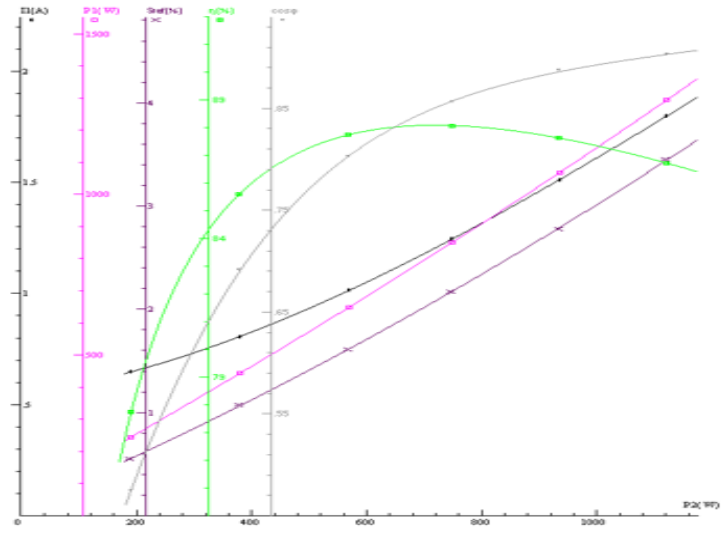

Model Number	SS3-TN-56HC-2-D-1-230 460-60
MFG PN	TSSN56H1U2B
List Price	--
Base Frame	SS-56HC-SS-TN

FRAME:    HP:    RPM:    PHASE:    VOLT:    ENCL:    FREQ:    FLA:    LRA:

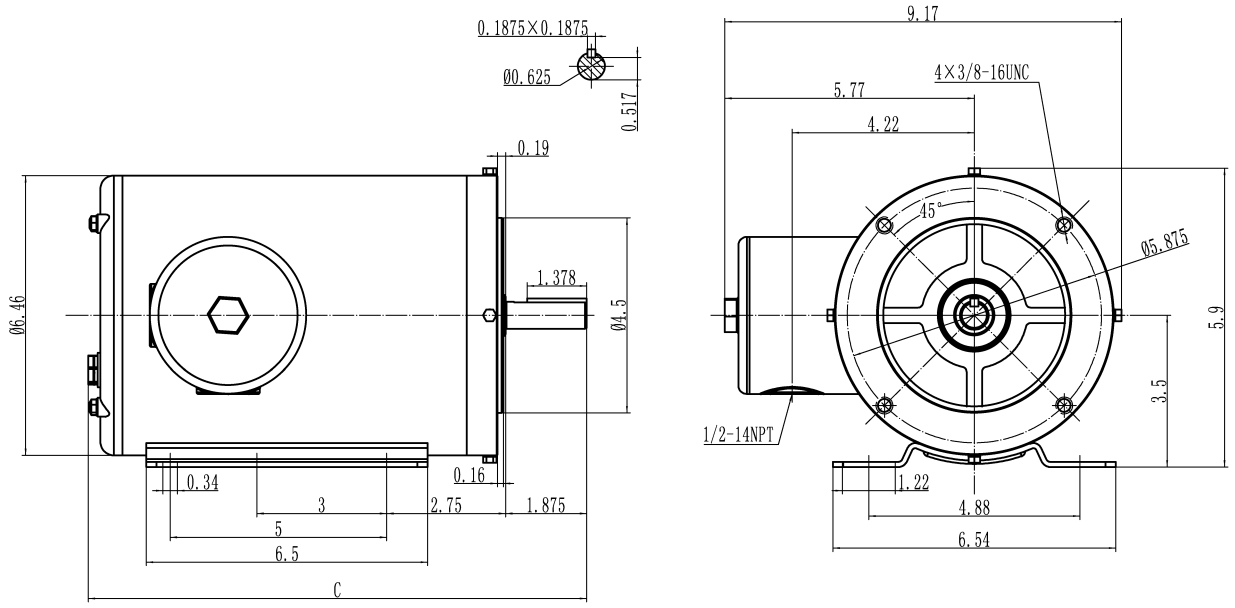

TSSN56H1U2B	1	11.6
TSSN56H1U4B	1	12.2
型号	功率 (HP)	C

	MODEL:	TSSN56H	SCALE: 1:2	DATE:	UNITS:
	REV.DESC:		VERSION:	REVISED:	BY:
					WWW.TECHTOP.COM