



Model Number	SS3-TN-56C-2-D-0.75-RND-230 460-60
MFG PN	TSSN56 3/4U2B
List Price	--

All data shown at HIGH voltage setting

Format STD 3 Phase

Electrical Data		General Data	
Rated Motor Output Power	0.75 HP	Frame Size	56
Rated Motor Speed	3510 r/min	Enclosure	TENV
Rated Motor Voltage (3 Phase)	230 460-60 Volts - HZ	Approximate Weight	38.7
Rated Motor Current	1.96/0.98 Amps	NEMA Design	B
Service Factor	1.25	IP Rating	69K
KVA Code	M	Insulation Class	F
Nominal Efficiency	84.5 %	Tropicalization	YES
Nominal Power Factor	0.85 cosθ	Duty	Cont.
Full Load Torque Ft-Lb	1.113776 Ft-Lb	Cable Entry	0
Temp Rise @ Full Load °C	48.9	Feet Removable	NO
Efficiency Level	IE3 - NEMA Premium	Double Drilled	0

Load Data	RPM	Trq %FL	Current Amps	Mechanical Data	
Locked Rotor	-	285	9.1	Rated Ambient (°C)	40
Breakdown	-	391	-	Rated Altitude (M)	1000
Pull Up	-	230	-	Coating	unpainted - unpainted
125% of FL	3489	-	1.15	Shaft Grounding	NO
75% of FL	3536	-	0.77	Brake Voltage (DC)	--
50% of FL	3558	-	0.61	Brake Torque (N-M)	--
No Load	--	-	0.43		

Load Data		Current Amps		Mechanical Data	
Hazardous	--			Bearing DE Side	6205 2RS
Location				Bearing NDE Side	6204 2RS
				Moment of Inertia	-- kg.m2
				Noise Level	Per NEMA dB (A)

CT VFD Range	--	Loaded Torque Curves	--
P1 = INPUT POWER (KW), S = Slip (% of Sync RPM), η = Efficiency (%), cosφ = Power Factor			

Certifications	UL	CSA	DOE
File Numbers	323353	224693	096A

Wiring Diagram 3PH 9 Lead Dual Voltage

3 Phase - YY/Y - 9 Lead
 4,1 Blue / 5,2 White / 6,3 Org / 7 Yl / 8 Blk / 9 RD
 Cast Iron- 1,2,3 Top - 4,5,6,7,8,9 Bottom
 Aluminum - 4,5,6,8,9 Top - 1,2,3,7 Bottom

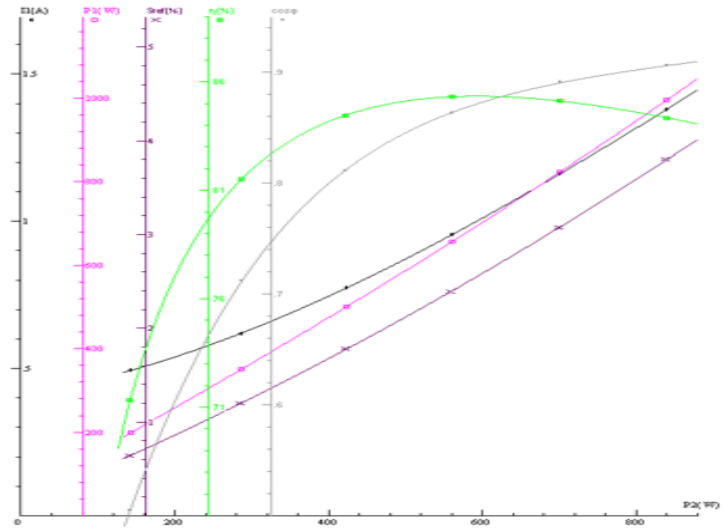
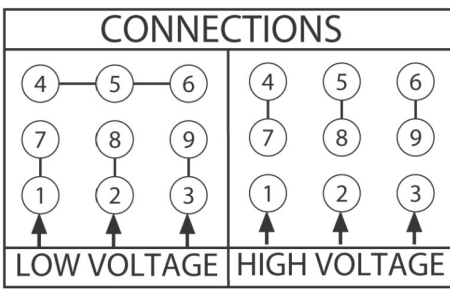

Model Number	SS3-TN-56C-2-D-0.75-RND-230 460-60
MFG PN	TSSN56 3/4U2B
List Price	--
Base Frame	RN-56C-SS-TN

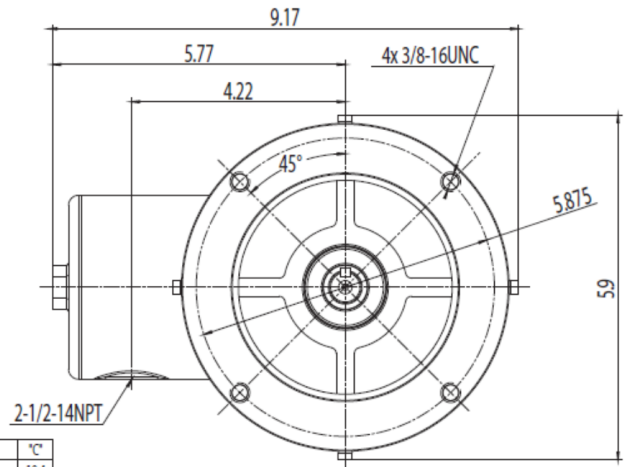
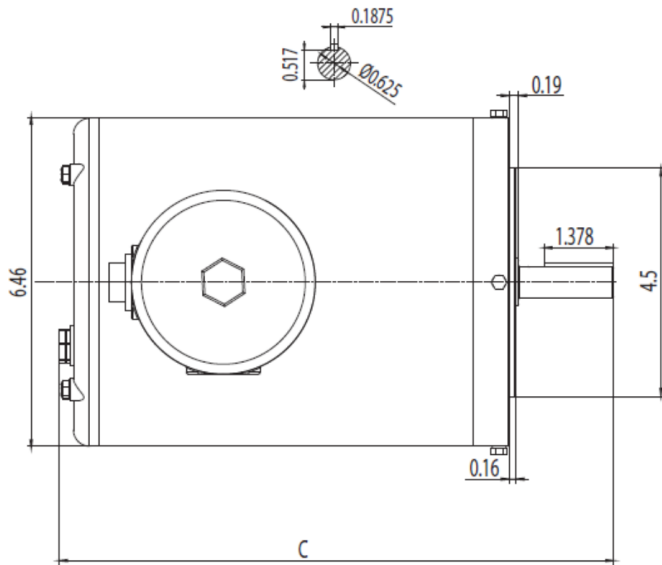

HP	°C
0.5 2P	10.4
0.33 4P	10.4
0.5 4P	11
0.75 2P	11
0.75 4P	11.6

MODEL NUMBER	RN-56C-AL-TN	ISSUE DATE:	5/2025
DIMENSIONS	IN		
CASTING MATERIAL	ALUMINUM	WWW.TECHTOPIND.COM	

Techtop Industries -2815 Colonnades Court - Peachtree Corners, GA 30071 - Phone: (678) 436-5540

Techtop Industries -2815 Colonnades Court - Peachtree Corners, GA 30071 - Phone: (678) 436-5540