



**Model Number** SD3-365TSC-2-BR-E-75-460-60

**MFG PN** T365TS75U2B

**List Price** --

All data shown at HIGH voltage setting

Format STD 3 Phase

Electrical Data				General Data	
Rated Motor Output Power	75 HP			Frame Size	365
Rated Motor Speed	3560 r/min			Enclosure	TEFC
Rated Motor Voltage (3 Phase)	460-60 Volts - HZ			Approximate Weight	881
Rated Motor Current	82.5 Amps			NEMA Design	B
Service Factor	1.15			IP Rating	56
KVA Code	G			Insulation Class	F
Nominal Efficiency	93.6 %			Tropicalization	YES
Nominal Power Factor	0.91 cosθ			Duty	Cont.
Full Load Torque Ft-Lb	149.35 Ft-Lb			Cable Entry	1.25
Temp Rise @ Full Load °C	72.4			Feet Removable	YES
Efficiency Level	IE3 - NEMA Premium			Double Drilled	NO
Load Data	RPM	Trq %FL	Current Amps	Rated Ambient (°C)	40
Locked Rotor	-	172	545.6	Rated Altitude (M)	1000
Breakdown	-	222	-	Coating	7024 - Graphite Grey
Pull Up	-	84	-	Shaft Grounding	YES
125% of FL	3548	-	103.85	Brake Voltage (DC)	--
75% of FL	3571	-	61.11	Brake Torque (N-M)	--
50% of FL	3581	-	42.35	Mechanical Data	
No Load	--	-	15.64	Bearing DE Side	6313 C3
Hazardous Location	CL1 Div2 Grp A,B,C,D			Bearing NDE Side	6313 C3
				Moment of Inertia	-- kg.m2
				Noise Level	Per NEMA dB (A)
CT VFD Range		--		Loaded Torque Curves	
				<b>P1 = INPUT POWER (KW), S = Slip (% of Sync RPM), η = Efficiency (%), cosφ = Power Factor</b>	
Certifications	UL	CSA	DOE		
File Numbers	323353	224693	096A		
Wiring Diagram	3PH Single Voltage SD3				

Model Number	SD3-365TSC-2-BR-E-75-460-60
MFG PN	T365TS75U2B
List Price	--
Base Frame	SD-365TSC-CI-TF

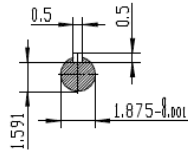
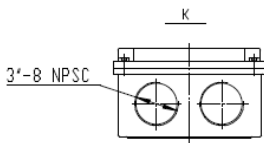
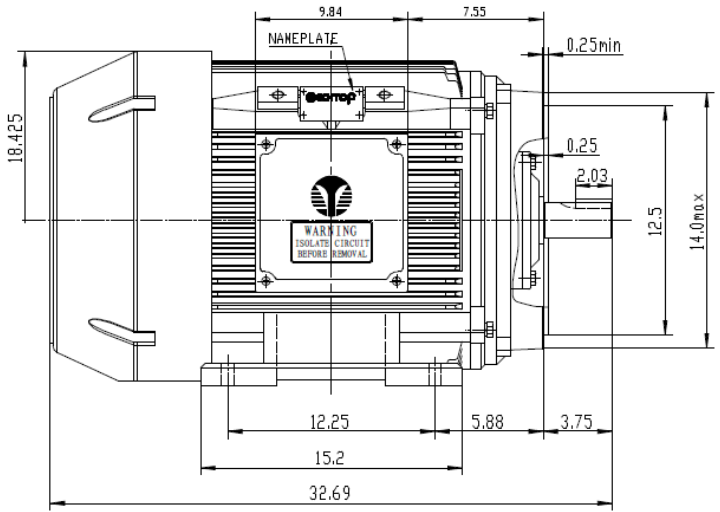
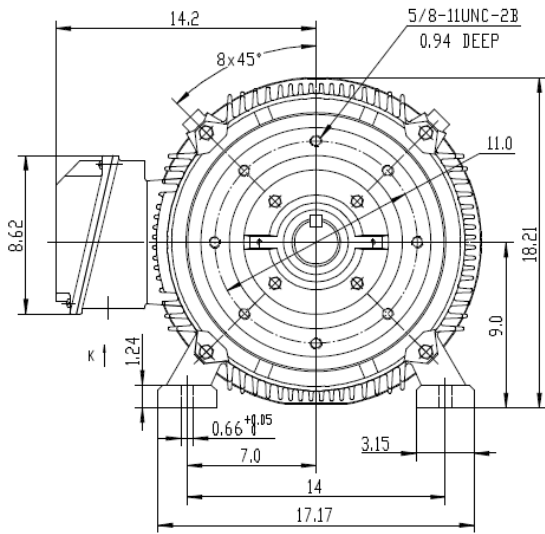

 ShangHai HIMAK Electrical Machinery CO., LTD		NEMA TEFC 365TSC CFC		
		NO:	1HMY.010.026	
Design	Standard	STEP MARK	1:5	SORT Cast iron Motor
Checker	Allow			
Auditing	Date			