



Model Number

SD3-324TC-6-BR-E-25-460-60

MFG PN

T324T25U6B

List Price

--

All data shown at HIGH voltage setting

Format STD 3 Phase

**Electrical Data**

**General Data**

Rated Motor Output Power	25 HP	Frame Size	324
Rated Motor Speed	1175 r/min	Enclosure	TEFC
Rated Motor Voltage (3 Phase)	460-60 Volts - HZ	Approximate Weight	526.6
Rated Motor Current	31.9 Amps	NEMA Design	B
Service Factor	1.25	IP Rating	56
KVA Code	G	Insulation Class	F
Nominal Efficiency	93 %	Tropicalization	YES
Nominal Power Factor	0.79 cosθ	Duty	Cont.
Full Load Torque Ft-Lb	-- Ft-Lb	Cable Entry	1.25
Temp Rise @ Full Load °C	59.6	Feet Removable	YES
Efficiency Level	IE3 - NEMA Premium	Double Drilled	NO

Load Data	RPM	Trq %FL	Current Amps	General Data	
Locked Rotor	-	151	4.63	Rated Ambient (°C)	40
Breakdown	-	173	-	Rated Altitude (M)	1000
Pull Up	-	98	-	Coating	7024 - Graphite Grey
125% of FL	1173	-	36.6	Shaft Grounding	YES
75% of FL	1184	-	24.17	Brake Voltage (DC)	--
50% of FL	1190	-	17.96	Brake Torque (N-M)	--
No Load	1196	-	10.81	Mechanical Data	

Hazardous Location	CL1 Div2 Grp A,B,C,D			Bearing DE Side	6312 C3
				Bearing NDE Side	6312 C3
				Moment of Inertia	-- kg.m2
				Noise Level	Per NEMA dB (A)

CT VFD Range	--	<b>Loaded Torque Curves</b>	
		P1 = INPUT POWER (KW), S = Slip (% of Sync RPM), η = Efficiency (%), cosφ = Power Factor	

Certifications	UL	CSA	DOE
File Numbers	323353	224693	096A

Wiring Diagram 3PH Single Voltage SD3

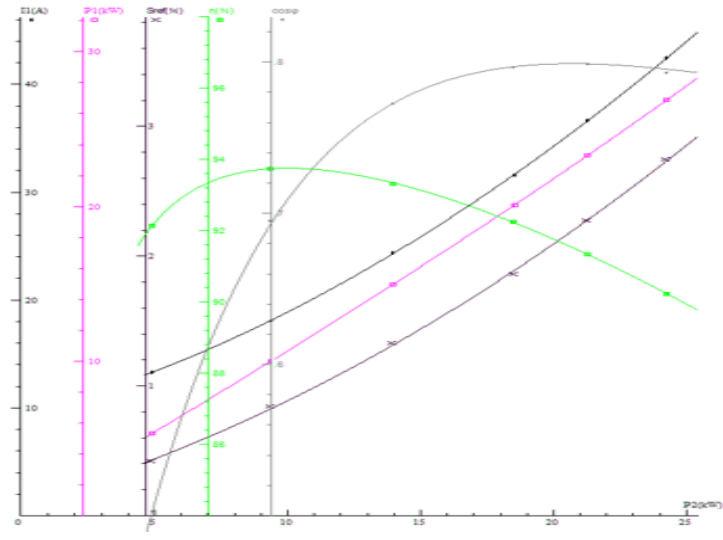
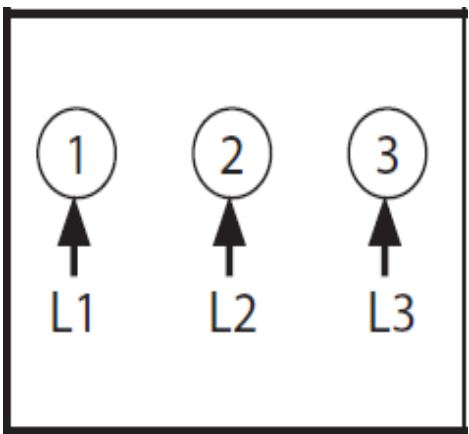

Model Number	SD3-324TC-6-BR-E-25-460-60
MFG PN	T324T25U6B
List Price	--
Base Frame	SD-324TC-CI-TF

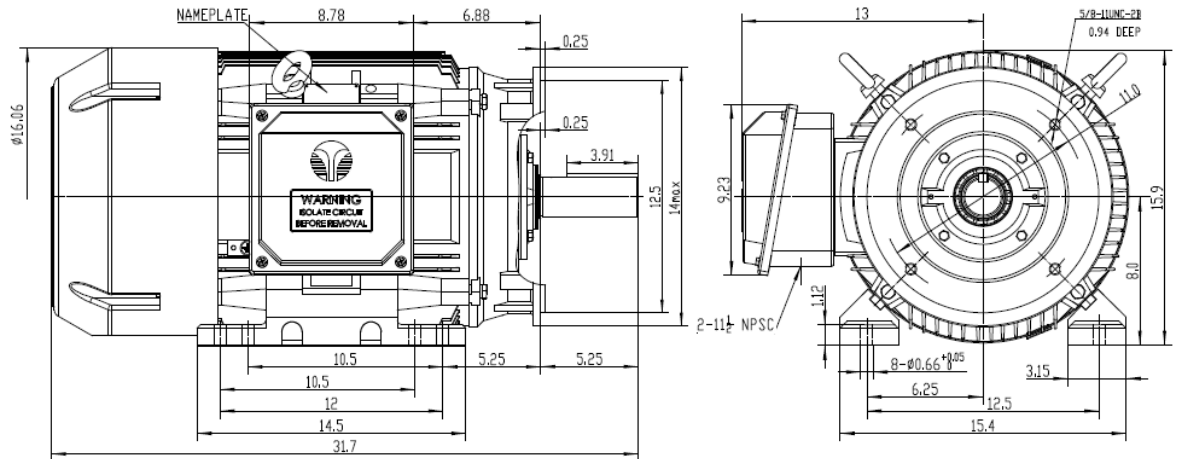

**NOTES:**

1. All Cast Iron Construction
2. Design B
3. IP55 Labyrinth seals on DE and DDE
4. H Class Insulation System
5. Max Winding Temperature rise 80°C
6. Max bearing temperature rise 45°C for 4 pole and 50°C for 2 pole motors when direct coupled.
7. Regreasable bearings
8. External Grounding provisions
9. Maximum foot flatness deviation .127 mm
10. Conductive Polymer Cooling Fan
11. Diagonally Split Conduit Box rotatable In 90° Increments
12. Lead seals In conduit box
13. Maximum no load sound power 85 dBA(2 pole),  
Maximum no load sound power 70 dBA(4 pole),  
Maximum no load sound power 64 dBA(6 pole).
14. No Load Motor Vibration not to exceed  
a.Radial 60HZ - 2.03mm/s (2,4 pole) and 1.52mm/s (6 pole)  
b.Axial 60HZ - 1.52mm/s
15. 300 series Stainless Steel hardware
16. Epoxy Coating meeting ASTM B117-97 for 96 h
17. All internal surfaces coated with anti-corrosion coating.
18. Internal Shaft Grounding brush Installed on drive end.
19. No Load test report Included with motor

 <b>Shanghai HIMAK Electrical Machinery CO., LTD</b>		EMA TEFC 326TC	
		IEEE-841 UNITS:INCH	
Design	Standard	NO:	CY257.A21.004
Checker	Allow	STEP MARK	1:5 SORT Cast iron Motor
Auditing	Date		