



**Model Number** SD3-213TC-4-BR-E-7.5-460-60

**MFG PN** T213T7.5U4B

**List Price** --

All data shown at HIGH voltage setting

Format STD 3 Phase

Electrical Data				General Data	
Rated Motor Output Power	7.5 HP			Frame Size	213
Rated Motor Speed	1750 r/min			Enclosure	TEFC
Rated Motor Voltage (3 Phase)	460-60 Volts - HZ			Approximate Weight	167.8
Rated Motor Current	9.5 Amps			NEMA Design	B
Service Factor	1.25			IP Rating	56
KVA Code	H			Insulation Class	F
Nominal Efficiency	91.7 %			Tropicalization	YES
Nominal Power Factor	0.81 cosθ			Duty	Cont.
Full Load Torque Ft-Lb	14.78 Ft-Lb			Cable Entry	1.25
Temp Rise @ Full Load °C	47.7			Feet Removable	YES
Efficiency Level	IE3 - NEMA Premium			Double Drilled	NO
Load Data	RPM	Trq %FL	Current Amps	Rated Ambient (°C)	40
Locked Rotor	-	184	6.82	Rated Altitude (M)	1000
Breakdown	-	258	-	Coating	7024 - Graphite Grey
Pull Up	-	227	-	Shaft Grounding	YES
125% of FL	1454	-	13.24	Brake Voltage (DC)	--
75% of FL	1473	-	9.04	Brake Torque (N-M)	--
50% of FL	1482	-	6.9	Mechanical Data	
No Load	--	-	4.53	Bearing DE Side	6308ZZ
Hazardous Location	CL1 Div2 Grp A,B,C,D			Bearing NDE Side	6308ZZ
				Moment of Inertia	-- kg.m2
				Noise Level	Per NEMA dB (A)
CT VFD Range		--		Loaded Torque Curves	
				P1 = INPUT POWER (KW), S = Slip (% of Sync RPM), η = Efficiency (%), cosφ = Power Factor	
Certifications	UL	CSA	DOE		
File Numbers	323353	224693	096A		
Wiring Diagram	3PH Single Voltage SD3				

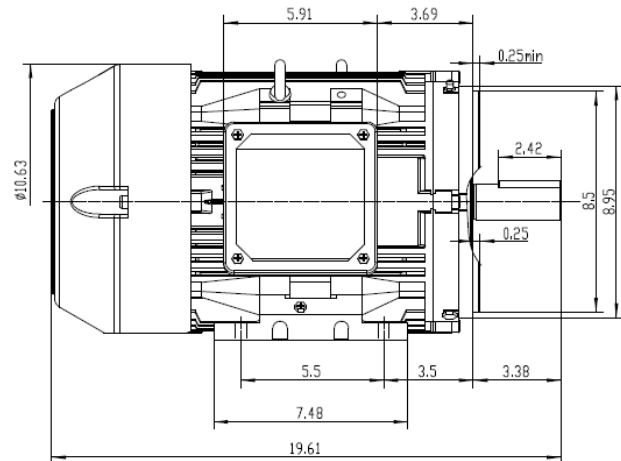
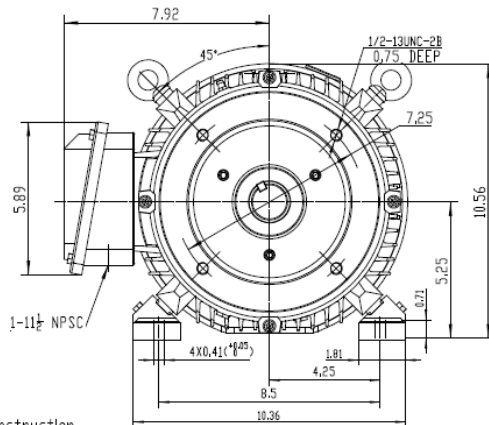

**NOTES:**

1. All Cast Iron Construction
2. Design B
3. IP55 Labyrinth seals on DE and DDE
4. H Class Insulation System
5. Max Winding Temperature rise 80°C
6. Max bearing temperature rise 45°C for 4 pole and 50°C for 2 pole motors when direct coupled.
7. Regreasable bearings
8. External Grounding provisions
9. Maximum foot flatness deviation .127 mm
10. Conductive Polymer Cooling Fan
11. Diagonally Split Conduit Box rotatable in 90° Increments
12. Lead seals In conduit box
13. Maximum no load sound power 85 dBA(2 pole),  
Maximum no load sound power 70 dBA(4 pole),  
Maximum no load sound power 64 dBA(6 pole).
14. No Load Motor Vibration not to exceed  
a.Radial 60HZ - 2.03mm/s (2,4 pole) and 1.52mm/s (6 pole)  
b.Axial 60HZ - 1.52mm/s
15. 300 series Stainless Steel hardware
16. Epoxy Coating meeting ASTM B117-97 for 96 h
17. All Internal surfaces coated with anti-corrosion coating.
18. Internal Shaft Grounding brush Installed on drive end.
19. No Load test report Included with motor

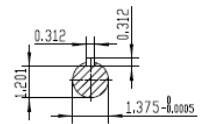

 Shanghai HIMAK Electrical Machinery CO., LTD		NEMA TEFC 213TC	
		IEEE-841 UNITS:INCH	
Design		NO:	CY254.A20.001
Checker		STEP MARK	1:3.5 SORT Cast iron Motor
Auditing			
Standard	Allow		
	Date		