



Model Number

SD3-184T-2-BR-E-5-460-60

MFG PN

T184T5U2B

List Price

--

All data shown at HIGH voltage setting

Format STD 3 Phase

Electrical Data

General Data

Rated Motor Output Power	5 HP	Frame Size	184
Rated Motor Speed	3510 r/min	Enclosure	TEFC
Rated Motor Voltage (3 Phase)	460-60 Volts - HZ	Approximate Weight	95.7
Rated Motor Current	5.7 Amps	NEMA Design	B
Service Factor	1.25	IP Rating	56
KVA Code	J	Insulation Class	F
Nominal Efficiency	88.5 %	Tropicalization	YES
Nominal Power Factor	0.92 cosθ	Duty	Cont.
Full Load Torque Ft-Lb	10.15 Ft-Lb	Cable Entry	1.25
Temp Rise @ Full Load °C	34.1	Feet Removable	YES
Efficiency Level	IE3 - NEMA Premium	Double Drilled	NO

Load Data	RPM	Trq %FL	Current Amps	Rated Ambient (°C)	40
Locked Rotor	-	178	8.3	Rated Altitude (M)	1000
Breakdown	-	268	-	Coating	7024 - Graphite Grey
Pull Up	-	137	-	Shaft Grounding	YES
125% of FL	3480	-	7.2	Brake Voltage (DC)	--
75% of FL	3534	-	4.32	Brake Torque (N-M)	--
50% of FL	3.1	-	--	Mechanical Data	
No Load	3597	-	1.53	Bearing DE Side	6306ZZ

CL1 Div2 Grp A,B,C,D

Bearing NDE Side	6306ZZ
Moment of Inertia	-- kg.m2
Noise Level	Per NEMA dB (A)

Loaded Torque Curves

P1 = INPUT POWER (KW), S = Slip (% of Sync RPM), η = Efficiency (%), cosφ = Power Factor

Certifications	UL	CSA	DOE
File Numbers	323353	224693	096A

Wiring Diagram 3PH Single Voltage SD3

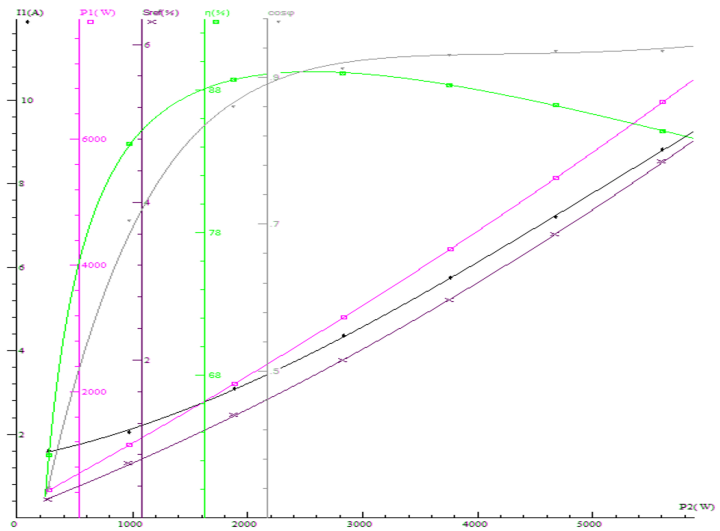
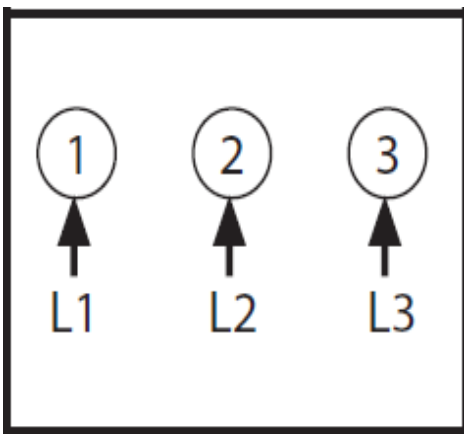

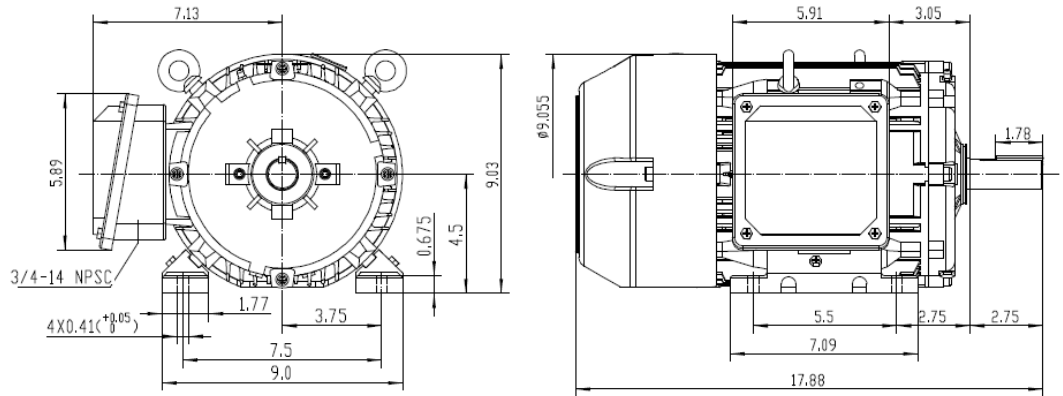



NOTES:

1. All Cast Iron Construction
2. Design B
3. IP55 Labyrinth seals on DE and DDE
4. H Class Insulation System
5. Max Winding Temperature rise 80°C
6. Max bearing temperature rise 45°C for 4 pole and 50°C for 2 pole motors when direct coupled.
7. Regreasable bearings
8. External Grounding provisions
9. Maximum foot flatness deviation .127 mm
10. Conductive Polymer Cooling Fan
11. Diagonally Split Conduit Box rotatable In 90° Increments
12. Lead seals in conduit box
13. Maximum no load sound power 85 dBA(2 pole), Maximum no load sound power 70 dBA(4 pole), Maximum no load sound power 64 dBA(6 pole).
14. No Load Motor Vibration not to exceed
 a. Radial 60HZ - 2.03mm/s (2,4 pole) and 1.52mm/s (6 pole)
 b. Axial 60HZ - 1.52mm/s
15. 300 series Stainless Steel hardware
16. Epoxy Coating meeting ASTM B117-97 for 96 h
17. All internal surfaces coated with anti-corrosion coating.
18. Internal Shaft Grounding brush installed on drive end.
19. No Load test report Included with motor

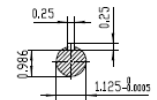
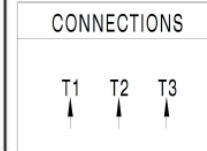
TECHTOP IEEE 841 SEVERE DUTY ELECTRIC MOTOR	
MODEL: SD3-184T-6BR-E-2	TECHTOP.COM
NEMA HP 60 Hz 2 50 Hz 2	MFG PN T 184T2U6B
RPM 1175 970	SER # 1603102013
VOLT(S) 460 380	DATE 06/08/02
FLA 3.1 3.6	DESIGN B
SF 1.25 1	FRAME 184T
KVA CODE J H	ENCL TEFC
NOM EFF 0.885	IP 55
	Cont. Cont.
	DUTY S1
	INS CL 40 °C
	AMB 40 °C
	WEIGHT 121.4 lbs
	Emp Inlet 22493
	MADE IN CHINA



 Shanghai HIMAK Electrical Machinery CO., LTD		NEMA TEFC 184T-2HP-6P	
		IEEE-841 UNITS:INCH	
Design	Standard	NO:	CY253.A20.006
Checker	Allow	STEP MARK	1:3.5 SORT Cast iron Motor
Auditing	Date		