



Model Number

SD3-145T-4-BR-E-2-460-60

MFG PN

T145T2U4B

List Price

--

All data shown at HIGH voltage setting

Format STD 3 Phase

Electrical Data

General Data

Rated Motor Output Power	2 HP	Frame Size	145
Rated Motor Speed	1740 r/min	Enclosure	TEFC
Rated Motor Voltage (3 Phase)	460-60 Volts - HZ	Approximate Weight	58.9
Rated Motor Current	2.8 Amps	NEMA Design	B
Service Factor	1.25	IP Rating	56
KVA Code	K	Insulation Class	F
Nominal Efficiency	86.5 %	Tropicalization	YES
Nominal Power Factor	0.78 cosθ	Duty	Cont.
Full Load Torque Ft-Lb	8.42 Ft-Lb	Cable Entry	1.25
Temp Rise @ Full Load °C	50	Feet Removable	YES
Efficiency Level	IE3 - NEMA Premium	Double Drilled	NO

Load Data	RPM	Trq %FL	Current Amps	Rated Ambient (°C)	40
Locked Rotor	-	282	7.48	Rated Altitude (M)	1000
Breakdown	-	304	-	Coating	7024 - Graphite Grey
Pull Up	-	175	-	Shaft Grounding	YES
125% of FL	1722	-	3.36	Brake Voltage (DC)	--
75% of FL	1758	-	2.26	Brake Torque (N-M)	--
50% of FL	1772	-	1.85	Mechanical Data	
No Load	1799	-	1.46	Bearing DE Side	6205ZZ

Hazardous Location	CL1 Div2 Grp A,B,C,D	Moment of Inertia	-- kg.m2
		Noise Level	Per NEMA dB (A)
		Loaded Torque Curves	
		--	

CT VFD Range

--

P1 = INPUT POWER (KW), S = Slip (% of Sync RPM), η = Efficiency (%), cosφ = Power Factor

Certifications	UL	CSA	DOE
File Numbers	323353	224693	096A

Wiring Diagram 3PH Single Voltage SD3

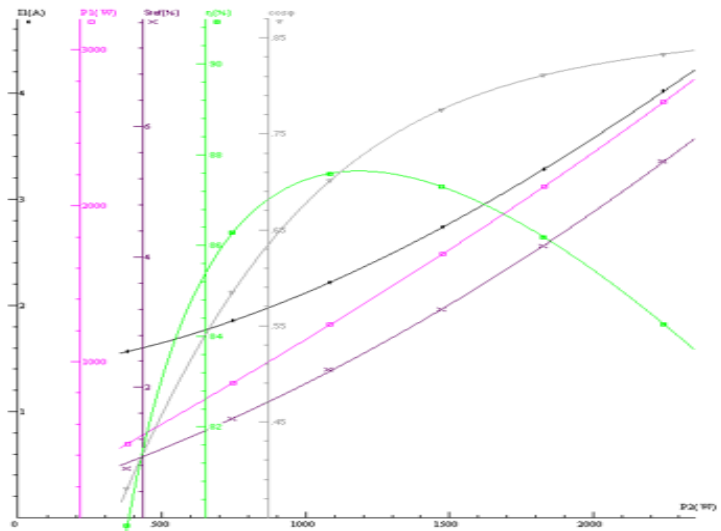
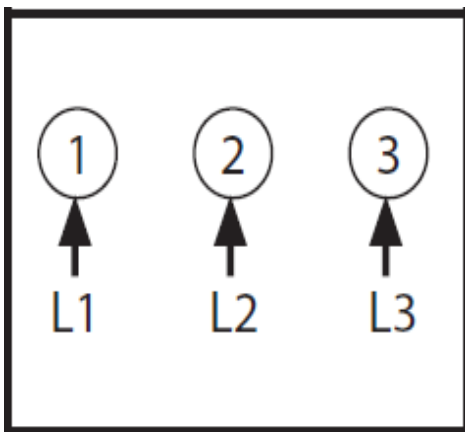

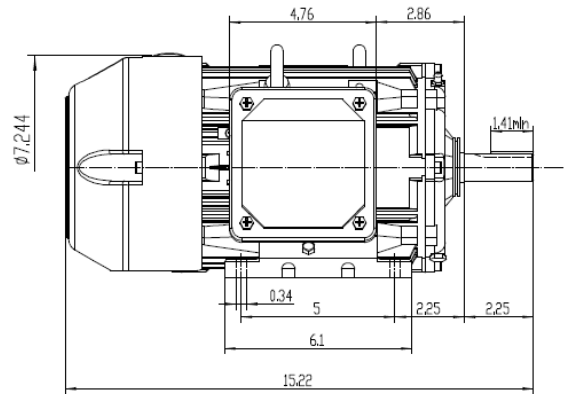
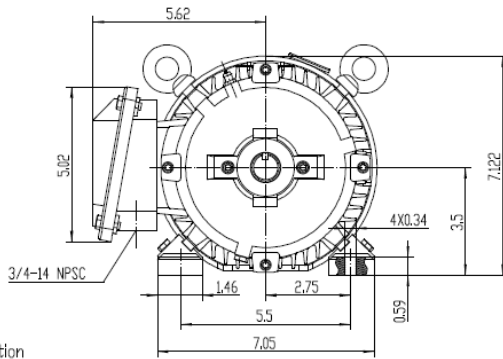

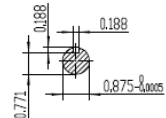

NOTES:

1. All Cast Iron Construction
2. Design B
3. IP55 Labyrinth seals on DE and ODE
4. H Class Insulation System
5. Max Winding Temperature rise 80°C
6. Max bearing temperature rise 45°C for 4 pole and 50°C for 2 pole motors when direct coupled.
7. Regreaseable bearings
8. External Grounding provisions
9. Maximum foot flatness deviation .127 mm
10. Conductive Polymer Cooling Fan
11. Diagonally Split Conduit Box rotatable in 90° Increments
12. Lead seals in conduit box
13. Maximum no load sound power 85 dBA(2 pole),
Maximum no load sound power 70 dBA(4 pole),
Maximum no load sound power 64 dBA(6 pole).
14. No Load Motor Vibration not to exceed
a.Radial 60HZ - 2.03mm/s (2,4 pole) and 1.52mm/s (6 pole)
b.Axial 60HZ - 1.52mm/s
15. 300 series Stainless Steel hardware
16. Epoxy Coating meeting ASTM B117-97 for 96 h
17. All internal surfaces coated with anti-corrosion coating.
18. Internal Shaft Grounding brush Installed on drive end.
19. No Load test report included with motor

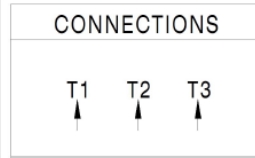

TECHTOP		IEEE 841		SEVERE DUTY	
				ELECTRIC MOTOR	
MODEL SD3-145T-4-BR-E-1.5			TECHTOP.COM		
NEMA 1.5		50 Hz 1410		MFG PN T 145T1.5U4B	
HP 1.5		RPM 1740		SER # 1603102005	
VOLT(ØV) 460		FLA 2.2		DATE 0688002	
SF 1.25		NOM.EFF 0.865		DESIGN B	
KVA CODE L		INS CL H		FRAME 145T	
NOM.EFF 0.865		AMB 40 °C		ENCL TEFC	
		WEIGHT 58 lbs		IP 55	
		MADE IN CHINA		DUTY Cont.	



 ShangHai HIMAK Electrical Machinery CO., LTD		NEMA TEFC 145T-1.5HP-4P	
		IEEE-841 UNITS:INCH	
Design	Standard	NO:	CY252.A20.005
Checker	Allow	STEP MARK	1:3 SORT Cast iron Motor
Auditing	Date		