



Model Number GR3-CI-TF-365TC-4-BR-D-75-230|460-60

MFG PN T365T75U4B

List Price --

All data shown at HIGH voltage setting

Format | STD 3 Phase

Electrical Data				General Data																									
Rated Motor Output Power	75 HP			Frame Size	365																								
Rated Motor Speed	1780 r/min			Enclosure	TEFC																								
Rated Motor Voltage (3 Phase)	230 460-60 Volts - HZ			Approximate Weight	850																								
Rated Motor Current	167.2/83.6 Amps			NEMA Design	A																								
Service Factor	1.15			IP Rating	55																								
KVA Code	K			Insulation Class	F																								
Nominal Efficiency	95.4 %			Tropicalization	YES																								
Nominal Power Factor	0.88 cosθ			Duty	Cont.																								
Full Load Torque Ft-Lb	224.2304 Ft-Lb			Cable Entry	1.25																								
Temp Rise @ Full Load °C	62.5			Feet Removable	YES																								
Efficiency Level	IE3 - NEMA Premium			Double Drilled	NO																								
Load Data	RPM	Trq %FL	Current Amps	Rated Ambient (°C)	40																								
Locked Rotor	-	328	829.5	Rated Altitude (M)	1000																								
Breakdown	-	297	-	Coating	7024 - Graphite Grey																								
Pull Up	-	165	-	Shaft Grounding	NO																								
125% of FL	1776	-	102.6	Brake Voltage (DC)	--																								
75% of FL	1786	-	64.35	Brake Torque (N-M)	--																								
50% of FL	1791	-	47.41	Mechanical Data																									
No Load	--	-	27.82	Bearing DE Side	6313 C3																								
Hazardous Location	Class 1, Div 2, Grp A,B,C,D			Bearing NDE Side	6313 C3																								
				Moment of Inertia	-- kg.m2																								
				Noise Level	Per NEMA dB (A)																								
CT VFD Range		--		Loaded Torque Curves																									
<p>P1 = INPUT POWER (KW), S = Slip (% of Sync RPM), η = Efficiency (%), cosφ = Power Factor</p>																													
Certifications	UL	CSA	DOE																										
File Numbers	323353	224693	096A																										
Wiring Diagram	3PH 9 Lead Dual Voltage																												
<p>3 Phase - YY/Y - 9 Lead 4,1 Blue / 5,2 White / 6,3 Org / 7 Yl / 8 Blk / 9 RD Cast Iron- 1,2,3 Top - 4,5,6,7,8,9 Bottom Aluminum - 4,5,6,8,9 Top - 1,2,3,7 Bottom</p>																													
<p>CONNECTIONS</p> <table border="1"> <tr> <td>4</td><td>5</td><td>6</td> <td>4</td><td>5</td><td>6</td> </tr> <tr> <td>7</td><td>8</td><td>9</td> <td>7</td><td>8</td><td>9</td> </tr> <tr> <td>1</td><td>2</td><td>3</td> <td>1</td><td>2</td><td>3</td> </tr> <tr> <td colspan="3">LOW VOLTAGE</td> <td colspan="3">HIGH VOLTAGE</td> </tr> </table>						4	5	6	4	5	6	7	8	9	7	8	9	1	2	3	1	2	3	LOW VOLTAGE			HIGH VOLTAGE		
4	5	6	4	5	6																								
7	8	9	7	8	9																								
1	2	3	1	2	3																								
LOW VOLTAGE			HIGH VOLTAGE																										
<p>Techtop Industries -2815 Colonnades Court - Peachtree Corners, GA 30071 - Phone: (678) 436-5540</p>																													

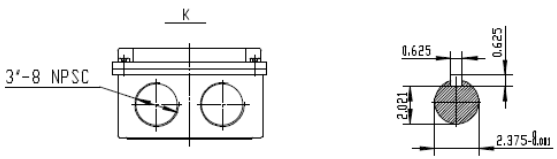
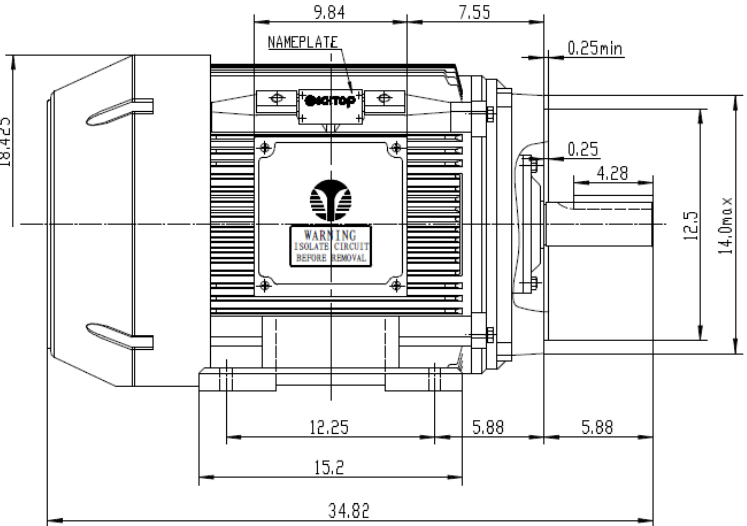
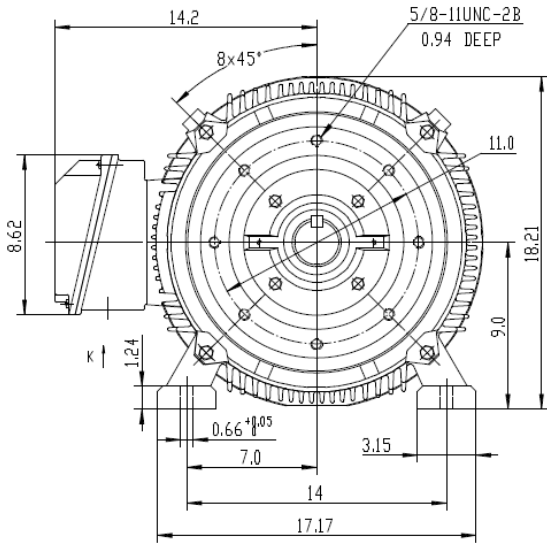

 ShangHai HIMAK Electrical Machinery CO.,LTD		NEMA TEFC 365TC CFC	
		NO:	1HMY.010.C028
Design	Standard	STEP MARK	1:5 SORT Cast iron Motor
Checker	Allow		
Auditing	Date		