



Model Number GR3-CI-TF-364TC-4-BR-D-60-230|460-60

MFG PN TFC364T60U4B

List Price --

All data shown at HIGH voltage setting

Format | STD 3 Phase

Electrical Data				General Data	
Rated Motor Output Power	60 HP			Frame Size	364
Rated Motor Speed	1780 r/min			Enclosure	TEFC
Rated Motor Voltage (3 Phase)	230 460-60 Volts - HZ			Approximate Weight	816
Rated Motor Current	136/68 Amps			NEMA Design	A
Service Factor	1.15			IP Rating	55
KVA Code	K			Insulation Class	F
Nominal Efficiency	95 %			Tropicalization	YES
Nominal Power Factor	0.87 cosθ			Duty	Cont.
Full Load Torque Ft-Lb	177.24528 Ft-Lb			Cable Entry	1.25
Temp Rise @ Full Load °C	54.9			Feet Removable	YES
Efficiency Level	IE3 - NEMA Premium			Double Drilled	NO
Load Data	RPM	Trq %FL	Current Amps	Rated Ambient (°C)	40
Locked Rotor	-	306	665	Rated Altitude (M)	1000
Breakdown	-	339	-	Coating	7024 - Graphite Grey
Pull Up	-	208	-	Shaft Grounding	NO
125% of FL	1779	-	83.89	Brake Voltage (DC)	
75% of FL	1788	-	52.43	Brake Torque (N-M)	
50% of FL	1792	-	38.97	Mechanical Data	
No Load		-	22.39	Bearing DE Side	6313 C3
Hazardous Location	Class 1, Div 2, Grp A,B,C,D			Bearing NDE Side	6313 C3
				Moment of Inertia	kg.m2
				Noise Level	Per NEMA dB (A)
CT VFD Range		--		Loaded Torque Curves	
				P1 = INPUT POWER (KW), S = Slip (% of Sync RPM), η = Efficiency (%), cosφ = Power Factor	
Certifications	UL	CSA	DOE		
File Numbers	323353	224693	096A		
Wiring Diagram	3PH 12 Lead Dual Voltage				

Model Number	GR3-CI-TF-364TC-4-BR-D-60-230 460-60
MFG PN	TFC364T60U4B
List Price	--
Base Frame	GR-364TC-CI-TF

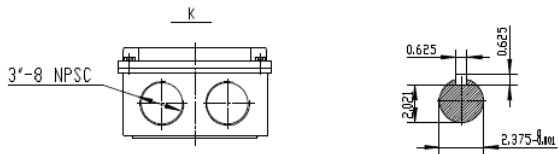
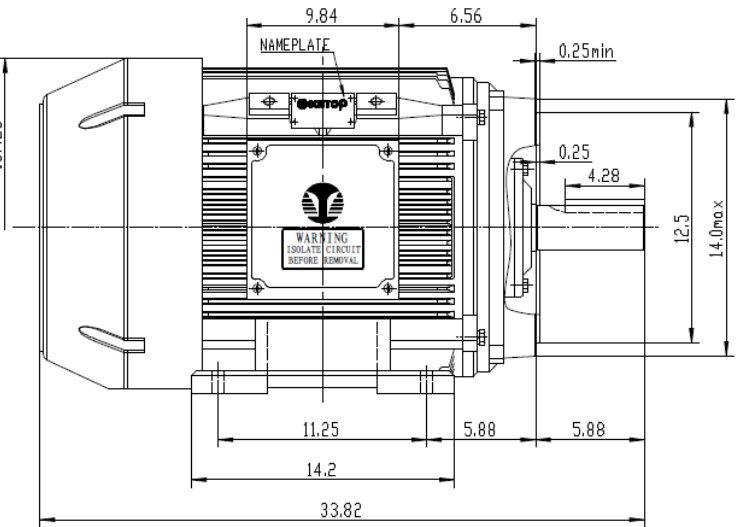
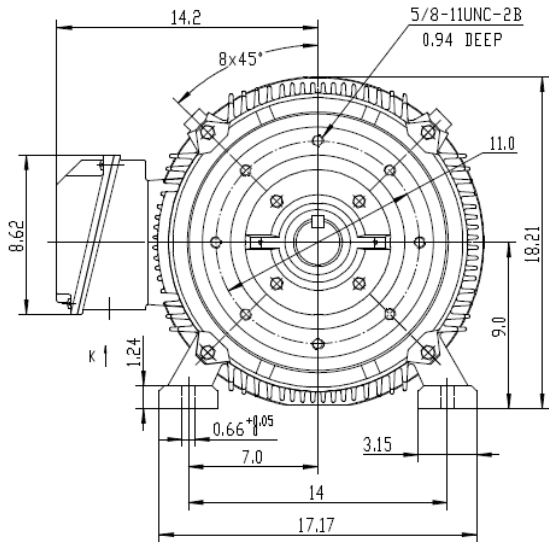

 ShangHai HIMAX Electrical Machinery CO.,LTD		NEMA TEFC 364TC CFC	
		NO:	1HMY.010.027
Design	Standard	STEP MARK	1:5 SORT Cast iron Motor
Checker	Allow		
Auditing	Date		