



Model Number GR3-CI-TF-213TC-2-B-D-7.5-230|460-60

MFG PN TFC213T7.5U2B

List Price --

All data shown at HIGH voltage setting

Format | STD 3 Phase

Electrical Data				General Data	
Rated Motor Output Power	7.5 HP			Frame Size	213
Rated Motor Speed	3520 r/min			Enclosure	TEFC
Rated Motor Voltage (3 Phase)	230 460-60 Volts - HZ			Approximate Weight	132
Rated Motor Current	17.4/8.7 Amps			NEMA Design	A
Service Factor	1.25			IP Rating	55
KVA Code	J			Insulation Class	F
Nominal Efficiency	89.5 %			Tropicalization	YES
Nominal Power Factor	0.9 cosθ			Duty	Cont.
Full Load Torque Ft-Lb	10.982864 Ft-Lb			Cable Entry	1.25
Temp Rise @ Full Load °C	51.5			Feet Removable	YES
Efficiency Level	IE3 - NEMA Premium			Double Drilled	NO
Load Data	RPM	Trq %FL	Current Amps	Rated Ambient (°C)	40
Locked Rotor	-	213	73	Rated Altitude (M)	1000
Breakdown	-	319	-	Coating	7024 - Graphite Grey
Pull Up	-	127	-	Shaft Grounding	NO
125% of FL	3500	-	10.61	Brake Voltage (DC)	
75% of FL	3544	-	6.4	Brake Torque (N-M)	
50% of FL	3564	-	4.7	Mechanical Data	
No Load	3586	-	2.34	Bearing DE Side	6308ZZ
Hazardous Location	Class 1, Div 2, Grp A,B,C,D			Bearing NDE Side	6308ZZ
				Moment of Inertia	kg.m2
				Noise Level	Per NEMA dB (A)
CT VFD Range		--		Loaded Torque Curves	
				P1 = INPUT POWER (KW), S = Slip (% of Sync RPM), η = Efficiency (%), cosφ = Power Factor	
Certifications	UL	CSA	DOE		
File Numbers	323353	224693	096A		
Wiring Diagram	3PH 9 Lead Dual Voltage				
3 Phase - YY/Y - 9 Lead 4,1 Blue / 5,2 White / 6,3 Org / 7 Yl / 8 Blk / 9 RD Cast Iron- 1,2,3 Top - 4,5,6,7,8,9 Bottom Aluminum - 4,5,6,8,9 Top - 1,2,3,7 Bottom					
CONNECTIONS 					

Model Number	GR3-CI-TF-213TC-2-B-D-7.5-230 460-60
MFG PN	TFC213T7.5U2B
List Price	--
Base Frame	GR-213TC-CI-TF

FRAME: 213TC | HP: | RPM: | PHASE: 3 | VOLT: 208 - 230/460V | ENCL: TEFC | FREQ: 60 Hz | FLA: | LRA:

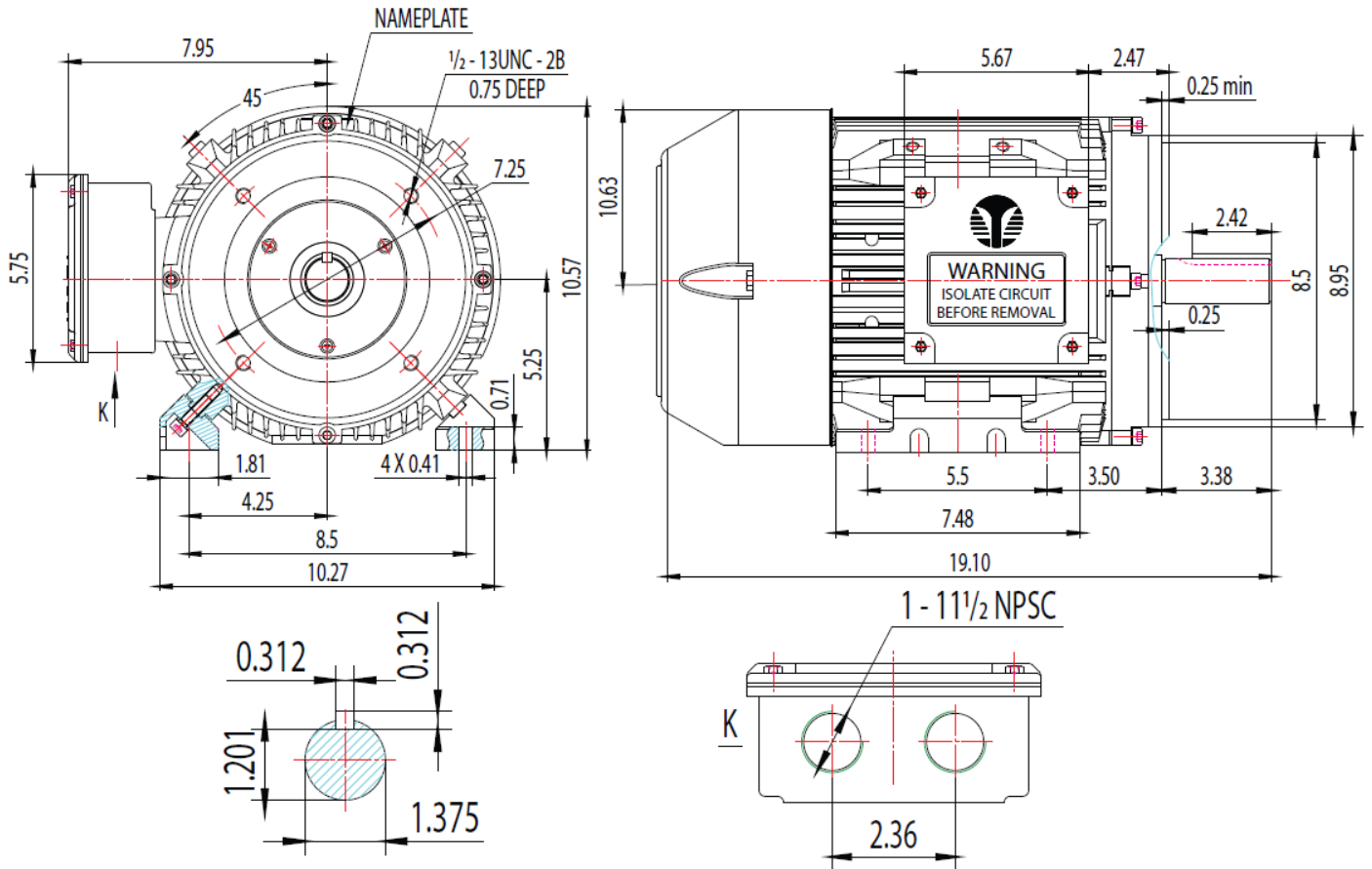

TECHTOP	MODEL NUMBER:	REV.	BY	DATE	CHANGES
	GR3-CI-TF-213TC	1			
MATERIAL:	MFG PN:	2			
UNITS: INCH	BY: SSEE	3			
DRAWN: 6/18/2018		4			
WWW.TECHTOP.COM		5			
		6			
		7			